

3/4 Yard Apartment Compactor

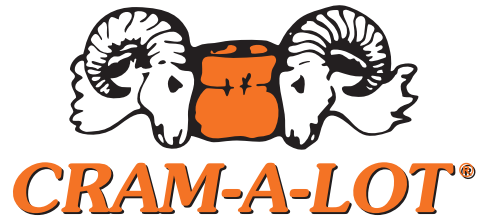

CS-.75 Wide Mouth Space Saver w/Twin Cylinders



"EQUIPPING THE WORLD FOR A BETTER ENVIRONMENT"™

wessco
WASTE & RECYCLING EQUIPMENT

Benefits of a CS-.75 Wide Mouth Apartment Compactor

CRAM-A-LOT® Apartment Compactors are designed to solve those extra tight space problems. The compactor packs into a 2yd or 3yd front load or rear load container where overall space utilization is critical. These powerful units are the perfect solution for high-rise apartments, hotels, hospitals, office buildings and anywhere else trash space is very limited.

Standard Features Include

- UL/CUL listed Control Panel
- Single side latching for easy and quick container removal
- ANSI Z245.2 & ANSI Z245.21 Compliant
- Quiet Operating Vane Pump
- Key operated controls
- Space saver design
- Special modifications quoted upon request

Design Features

- 36" Wide Charge Chamber
- Units can be equipped with high-rise chute hoppers, ground feed hoppers, and any other special installation solution requirement
- Rugged Construction provides long life
 - Floor – ½" AR 500 steel plate
 - Top – 3/8" steel plate
- Can be equipped with single side latching for easy and quick container removal
- Compaction ratios average 4 to 1, depending on material Excellent Compaction of dry and/or wet material

Loading Capabilities

- Load from ground, off a dock, multi-story chute or through the wall



Specifications

General

Length	62-7/8"
Width	49-7/8"
Height	46-1/4"
Clear top Opening	32-1/4" L x 36" W
Load Height	42"
Cycle Time	16 Sec

Total Pressure	
Normal	24,700 lbs
Maximum	28,200 lbs
Ram Face Pressure	
Normal	30.0 psi
Maximum	34.5 psi
Ram Penetration	6"
Ram Face Dimensions	35-7/8"W x 22-3/4" H
Weight	1965 Lb
WASTEC Rating	.6 cu yds

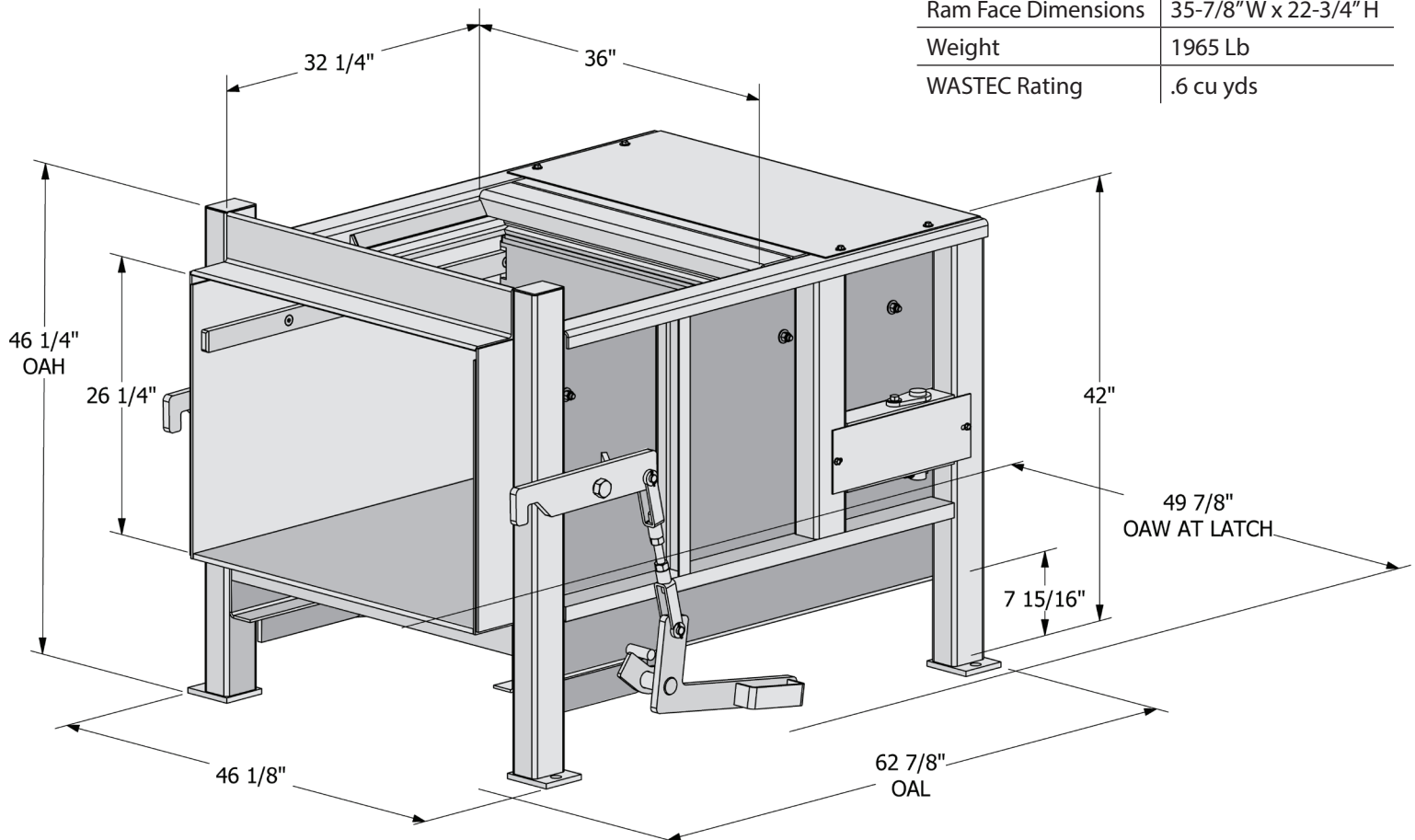

Hydraulic

Pump Type	Rotary vane positive displacement	
Pump Capacity	10.5 gpm @ 1800 rpm	
Tank Capacity	22 gal	
Hydraulic Cylinder pv(2)	Bore	3"
	Stroke	27"
	Rod	1-3/4"
Operating Pressure	Normal	1750 psi
	Maximum	2000 psi

Electrical

Motor	10 hp
Voltage	208/230/4801 VAC 60 Hz three phase
Optional Voltage	230 VAC 60 Hz Single Phase



CRAM-A-LOT®



Corporate Office

701 Butterfield Coach Rd. - P.O. Box 229 - Springdale, AR 72765-0229
1-800-678-7320 - 479-751-7320 - Fax: 479-872-0037

www.cram-a-lot.com