

Specialty Compactors

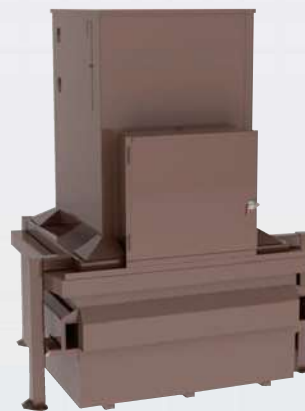

CRAM-A-LOT®
J.V. Manufacturing, Inc. 
Solid Waste & Recycling Equipment



“Equipping The World For A Better Environment”

Features

Our Cram-A-Lot specialty compactors are designed specifically for facilities to save space where overall space utilization is critical.

THESE POWERFUL UNITS ARE IDEAL FOR:

- Facilities with limited floor space
- Warehouses
- High-Rise Apartments
- Hotels, Offices & Hospitals
- Or anywhere else trash space is very limited

SAFE
SIMPLE
AND
USER
FRIENDLY

DESIGNED FOR:

- Ease of Installation
- Ease of Operation
- Ease of Maintenance

X-PRESS PACK

Portable Liquid Tight Self-Contained Unit

Ease of usage makes it a perfect portable trash compactor ready to use and requires no additional sight prep such as concrete pad, anchors or channel guides.



VERTICAL COMPACTOR

Small Footprint, Frontload service

This compact liquid tight compactor/container is designed to eliminate the need for multiple front load containers. Loading capabilities from the ground, off a dock, or through the wall with optional chute fed systems available.



APARTMENT COMPACTOR

Extra Tight Space Problems

Designed to solve those extra tight space problems, the apartment compactor packs into a 2yd or 3yd front load or rear load container. These units can be equipped with high-rise chute hoppers, ground feed hoppers, and any other special installation solution requirement.



CS-01 & CS-02

Limited volume applications

For restrictive applications, we offer a 1 or 2 yard short version of our standard commercial compactor.



Installed Applications



CRAM-A-LOT®
J.V. Manufacturing, Inc. 
Solid Waste & Recycling Equipment

Vertical Compactor



X-Press Pack



CS-02



CS-01



Apartment Compactor



Apartment Compactor



X-press Pack Self-Contained Compactor

The X-Press Pack is the easiest compactor on the market... just install it and start saving!!

FEATURES

- UL/CUL listed Control Panel
- Liquid tight compactor/container
- 4 or 6 cubic yard front load container
- Remote Power Unit
- Large 46 x 21 Charge Opening
- Low loading height for easy loading
- Optional chute fed systems available
- Fully (UHMW) guided & supported ram
- Fixed breaker bar teeth aid in trash retention
- ANSI Z245.21 Compliant



Available in 4yd & 6yd Container Capacities

This compact self-contained unit offers the same liquid tight containment as a standard size compactor but in a more compact size for space limitations. Designed to offer the same benefits of a larger unit with it's optional chute fed or hopper fed system.

Ease of usage makes it a perfect portable compactor ready to use and requires no additional sight prep such as concrete pad, anchors or channel guides.

DESIGN FEATURES

- Rugged Construction provides long life
- Can easily be used in long or short term locations.
- Eliminates the unsightly mess of spillage by hauler
- Excellent Compaction of dry and/or wet material
- Compaction ratios average 4 to 1, depending on material
- Ideal for Resturants, Fast Food locations, Shopping Centers, Supermarkets, Hospitals, Schools, Nursing Homes, and hotels

LOADING CAPABILITIES

- Load from ground, off a dock, or through the wall

USER FRIENDLY

- Container lid automatically unlocks when container is emptied and locks when returned.

SELF-CONTAINED UNIT

- Designed for limited space locations & wet or dry applications



CRAM-A-LOT®
J.V. Manufacturing, Inc.
Solid Waste & Recycling Equipment

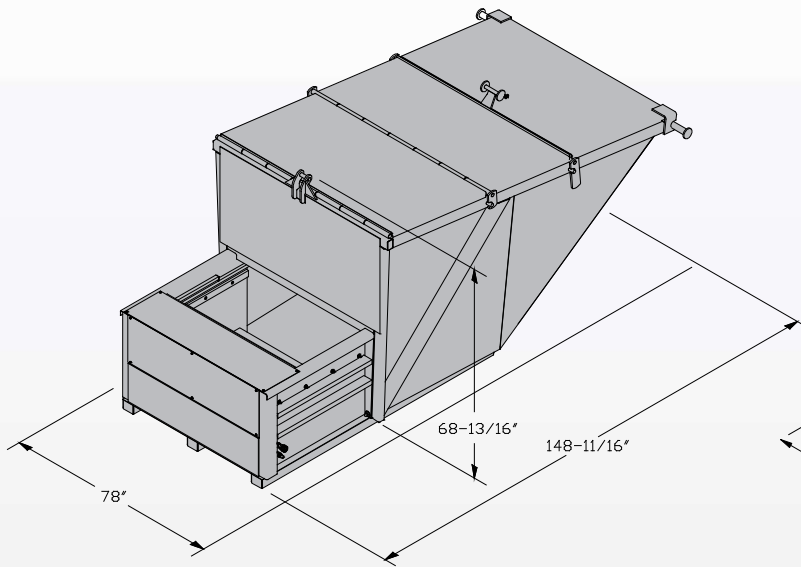

XP-6Y-RL

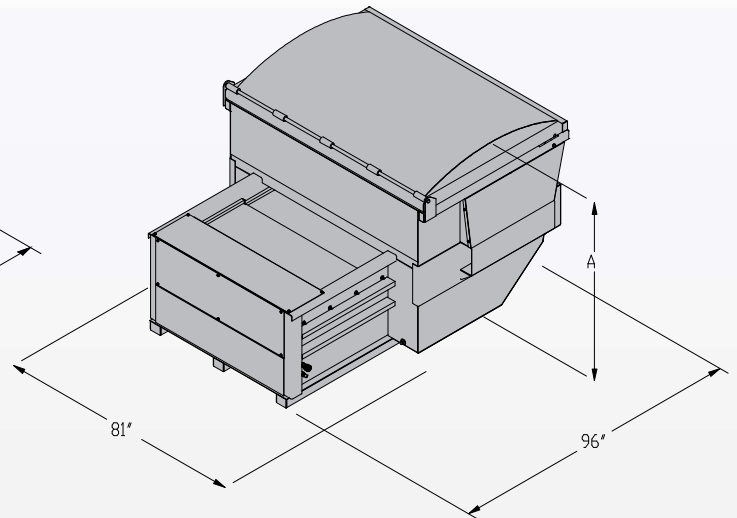

XP-4Y-FL

Special modifications quoted upon request

Specifications

GENERAL:

Dimensions	Length	96"
	Width	81"
	Height	See Chart
Clear Top Opening		21" L x 46" W
Minimum Load Height		32"
Cycle Time		27 seconds
Ram Force:	Normal	18,300 lbs
	Maximum	19,500 lbs
Ram Penetration		6" Minimum
Ram Face Dimensions		48" W x 19" H
Weight		See Chart
WASTEC Rated		.41 CU YDS

CONSTRUCTION:

Container	Floor	11 gage
	Sides	11 gage
Presshead	Top	3/16" Steel Plate
	Sides	3/16" Steel Plate
	Face	1/4" Steel Plate
Chassis	Floor	3/8" Steel Plate
		3" C-Channel
	Sides	3/16" Steel Plate 3" C-Channel

ELECTRICAL:

Motor	3 hp
Voltage	208-230/460 VAC 60 Hz Three Phase
Optional Voltage	230 VAC 60 Hz Single Phase

HYDRAULIC:

Pump Type		Vane
Pump Capacity		3 gpm
Tank Capacity		14 gal
Hydraulic Cylinder(2)	Bore	2-1/2"
	Stroke	18"
	Rod	1-1/4"
Operating Pressure	Normal	2,250 psi
	Maximum	2,400 psi

MODEL	A	WEIGHT
XP-4Y-FL	58 7/8"	2,700 lbs
XP-6Y-FL	76 7/8"	2,800 lbs
XP-6Y-RL	68 7/8"	2,975 lbs

All information is subject to engineering and/or other changes without notice.

Special modifications quoted upon request

Vertical Compactor - CV Series

Replaces Costly Open Containers - Requires Limited Space

FEATURES

- UL/CUL listed Control Panel
- Integral Power Unit
- Control Panel built into side of Compactor
- Key operated controls
- Automatic single-cycle operation
- Door safety interlock
- 3yd, 4yd, 6yd and 8yd container sizes available
- Wastec Rated



CRAM-A-LOT's CV line of Vertical Compactors are designed to save space and eliminate the need for multiple Front Load containers. This model is ideal for compacting all types of bagged waste, and features liquid tight containment

DESIGN FEATURES

- No hydraulic lines attached to the container eliminates the need for driver to exit the truck, saving time and money
- Eliminates the unsightly mess of spillage by the hauler
- Rugged construction provides long life
- Compaction Ratios on Average of 3.5 to 1 depending on material mix
- Ideal for Restaurants, Fast Food locations, Shopping Centers, Supermarkets, Hospitals, Schools, Nursing Homes, and hotels

LOADING CAPABILITIES

- Can be loaded from the front or rear
- Load from the ground, off a dock, or through the wall
- Feed heights starting at 46 ¾"

USER FRIENDLY

- Convenient location of control panel

SAFETY

- Door Safety Interlock
- Safe To Haul Light
- Removable key for authorized operator usage
- ANSI Z245.21 Compliant





CRAM-A-LOT®
J.V. Manufacturing, Inc.
Solid Waste & Recycling Equipment

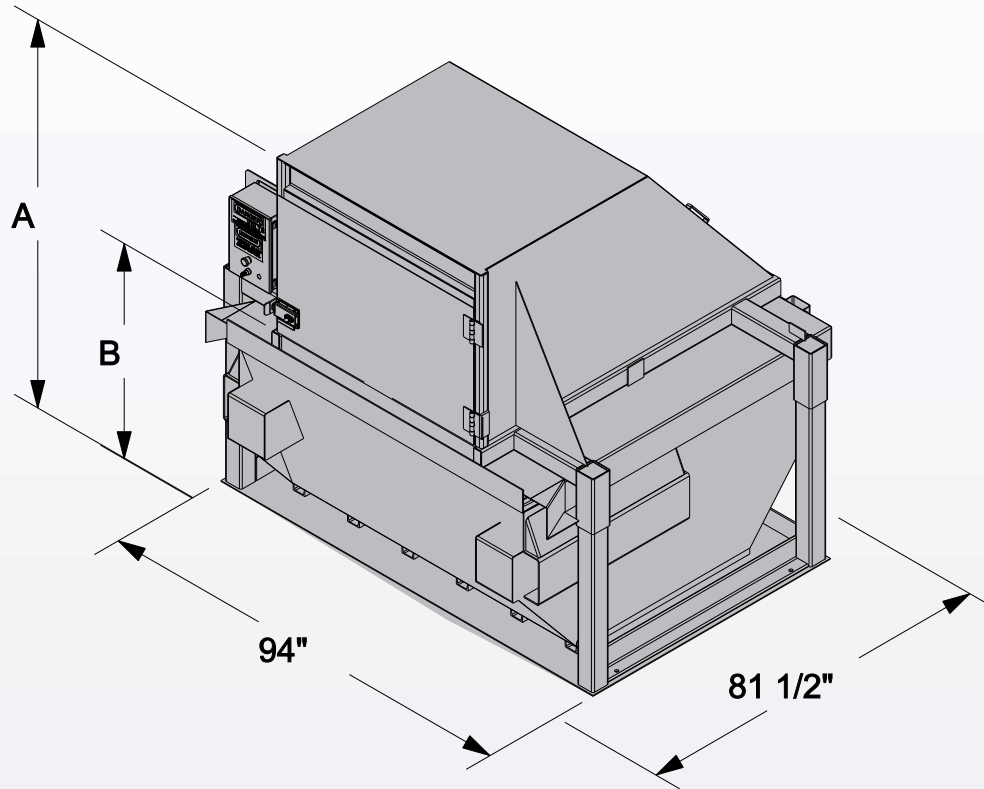

Special modifications quoted upon request

Specifications

GENERAL:

Dimensions	Length	81-1/2"
	Width	94"
Clear Top Opening		48" L x 31" W
Load Height		See Chart
Cycle Time		37 seconds
Ram Force	Normal	25,100 lbs
	Maximum	30,200 lbs
Ram Penetration		29.5"
Ram Face Dimensions		48" W x 35" L
Weight		See Chart
Ram Face Pressure	Normal	15.6
	Maximum	18.8

ELECTRICAL:

Motor	3 hp
Voltage	208-230/460 VAC 60 Hz Three Phase
Optional Voltage	230 VAC 60 Hz Single Phase

HYDRAULIC:

Pump Type		Vane
Pump Capacity		3 gpm
Tank Capacity		8 gal
Hydraulic Cylinder	Bore	4"
	Stroke	18"
	Rod	2"
Operating Pressure	Normal	2,000 psi
	Maximum	2,400 psi

CONSTRUCTION:

Container	Floor	11 gage
	Sides	11 gage
Presshead	Face	1/4" Steel Plate Sweeping Blade Design

MODEL	A	B	WEIGHT
CV-03	85"	47"	3,460 lbs
CV-04	85"	47"	3,625 lbs
CV-06	98"	60"	3,810 lbs
CV-08	112"	74"	4,145 lbs

All information is subject to engineering and/or other changes without notice.

Vertical Compactor - VCH Series

Four side loading options.....Five container options....All in ONE unit!!

FEATURES

- UL/CUL listed Control Panel
- Integral Power Unit
- Key operated controls
- 3yd, 4yd, 6yd and 8yd container sizes available
- Wastec rated

Cram-A-Lot VCH line of Vertical Compactors are designed to allow customized loading options along with versatility in container sizes allowing for volume growth without changing compactors

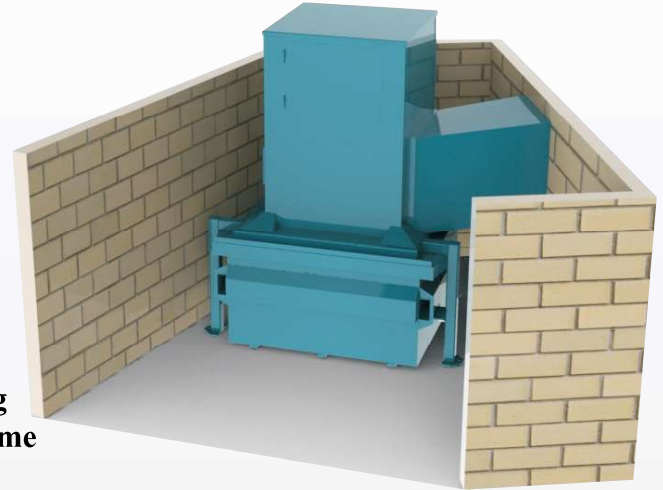

DESIGN FEATURES

- Sliding feed door is designed to eliminate trash from gathering on top of press head
- No hydraulic lines attached to the container eliminates the need for driver to exit the truck, saving time and money
- Eliminates the mess of spillage when emptying the container
- Rugged construction provides long life
- Compaction ratios average 4 to 1, depending on material mix
- Ideal for Restaurants, Fast Food locations, Shopping Centers, Supermarkets, Hospitals, Schools, Nursing Homes, and Hotels

LOADING CAPABILITIES

- The VCH serie offers loading capabilities from all 4 sides allowing user front, rear or side feed loading and can be combined with an open chute or thru-the-wall access for customized loading access
- Load from the ground, off a dock, or through the wall
- Feed heights starting at 40 1/4"

USER FRIENDLY

- Convenient location of controls

SAFETY

- Door Safety Interlock
- Highly visible "Safe To Haul Light"
- Removable key for authorized operator usage
- ANSI Z245.21 Compliant





CRAM-A-LOT®
J.V. Manufacturing, Inc.
Solid Waste & Recycling Equipment

Specifications

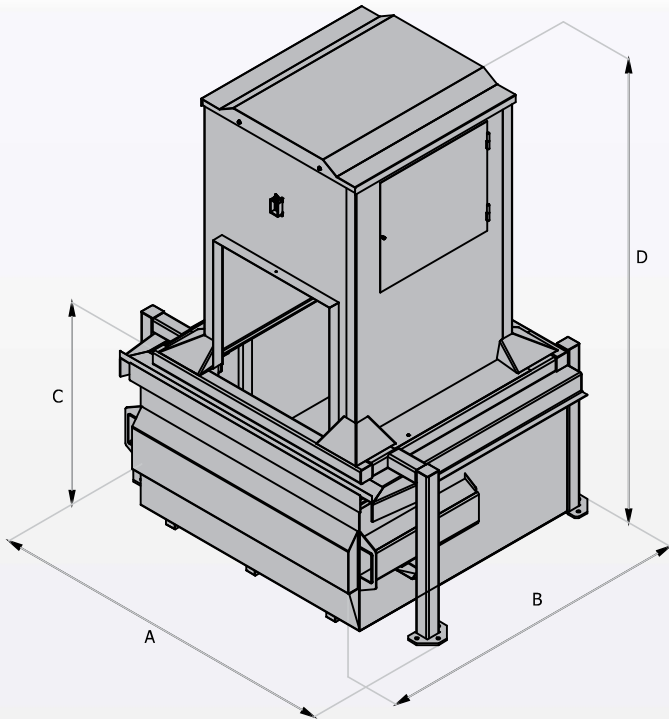

CONTAINER SIZE / TYPE	A	B	C	D	COMPACTOR WEIGHT
3-YD-FL	100"	79"	40-1/4"	115-1/4"	3892 lbs.
4-YD-FL	100"	79"	46-1/4"	121-1/4"	3973 lbs.
4-YD-RL	82"	100"	46-1/4"	121-1/4"	4050 lbs.
5-YD-FL	100"	79"	56-1/4"	131-1/4"	4183 lbs.
6-YD-FL	100"	95-1/2"	56-1/4"	131-1/4"	4294 lbs.
8-YD-FL	100"	95-1/2"	74"	150"	4510 lbs.

GENERAL:

Charge Box Capacity	See Chart
Dimensions	See Chart
Clear Top Opening	37 1/4"L x 38"W
Cycle Time	35 sec
Compaction Force	24,650 lbs.
Ram Face Pressure	11 psi
Ram Penetration	10"
Ram Face Dimensions	48"L x 48 "W
WASTEC Rated	2.08 Cu YDS

CONSTRUCTION

Container		
	Floor	11 ga
	Sides	11 ga 3" channel
	Trim	1-1/2" x 1-1/2" x 11 ga square tube
	Lift Pockets	Conform to WASTEC guidelines
Presshead	Sides	7 ga
	Face	1/4" Steel Plate Vertical Push
	Guides	UHMW strips
Chassis		Steel tube Frame 11 ga. Sheet Steel Shroud

ELECTRICAL:

Motor	5 hp
Voltage	208/230/460 Vac 60Hz Three Phase (230 Vac 60Hz single phase) (optional, 1 1/2hp)

HYDRAULIC:

Pump Type	VANE
Pump Capacity	6 gpm @ 1800 rpm
Tank Capacity	12 Gal
Hydraulic Cylinder x2	Bore 3" Stroke 37 1/4" Rod Dia. 2"
Operating Pressure	2000 Psi

All information is subject to engineering and/or other changes without notice.

Special modifications quoted upon request

Apartment Compactor

CA.5 1/2 Yard Space Saver Single Cylinder

CS.5 1/2 Yard Space Saver w/Twin Cylinders

FEATURES

- UL/CUL listed Control Panel
- Single side latching for easy and quick container removal
- ANSI Z245.21 Compliant
- Quiet Operating Vane Pump
- Key operated controls
- Can be equipped with high-rise chute hoppers, ground feed hoppers, and any other special installation solution requirement
- Space saver design
- Special modifications quoted upon request



CA.5

Cram-A-Lot Apartment Compactors are designed to pack into a 2yd or 3yd Front Load or Rear Load container where overall space utilization is critical

These powerful units are the perfect solution for high-rise apartments, hotels, hospitals, and office buildings, or anywhere space is very limited

DESIGN FEATURES

- Rugged Construction provides long life
- Compaction ratios average 4 to 1, depending on material
- Excellent Compaction of dry and/or wet material
- Ideal for apartment buildings, hotels, retail shops or anywhere space is limited

LOADING CAPABILITIES

- Load from ground, off a dock, multi-story chute or through the wall



CS.5



CRAM-A-LOT®
J.V. Manufacturing, Inc.
Solid Waste & Recycling Equipment

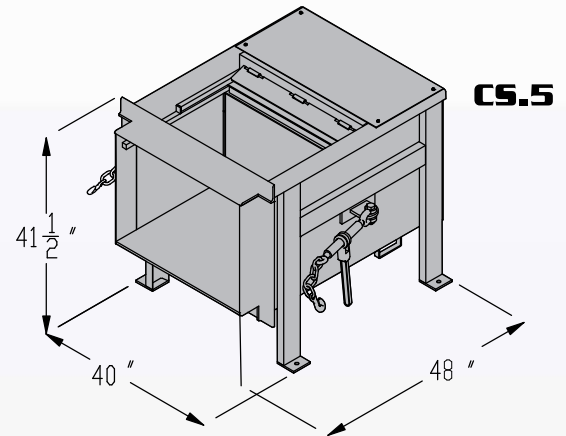
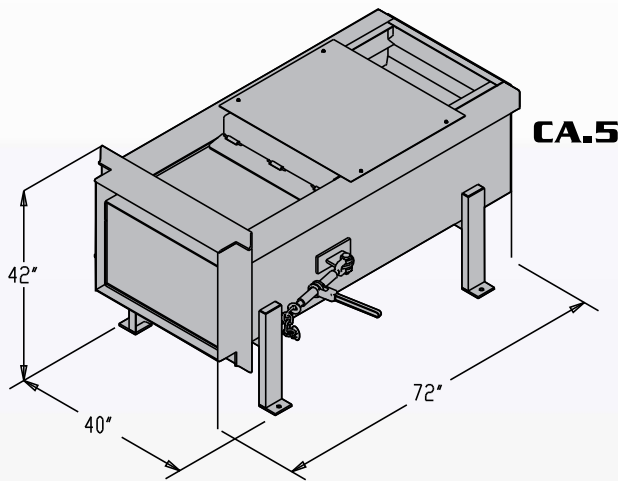

Special modifications quoted upon request

Specifications

CA-5 Specifications

GENERAL:

Dimensions	Length	72"
	Width	40"
	Height	42"
Clear Top Opening		20" L x 27" W
Load Height	Min	37-1/2"
Cycle Time		38 seconds
Ram Force	Normal	13,800 lbs
	Maximum	17,500 lbs
Ram Penetration		5.5"
Ram Face Dimensions		29-3/4" W x 18" H
Weight		1,840 lbs with hopper
WASTEC Rated		.27 CU YDS

CONSTRUCTION:

Chassis	Floor	1/4" Steel Plate 3" C-Channel
	Sides	1/4" Steel Plate 4" x 4" x 3/16 Steel Tube 4" C-Channel
Presshead	Top	3/16" Steel Plate
	Sides	1/4" Steel Plate
	Face	3/8" Steel Plate
	Bottom	3/8" AR Steel Plate
	Guides	HMW Pads
Breaker Bar		5" x 3-1/2" x 3/8" Steel Angle

ELECTRICAL:

Optional Voltage	Motor	3 hp
	Voltage	208-230/460 VAC 60 Hz Three Phase
		230 VAC 60 Hz Single Phase

HYDRAULIC:

Hydraulic Cylinder	Pump Type	Vane
	Pump Capacity	4.5 gpm
	Tank Capacity	11 gal
	Bore	4"
	Stroke	28"
Operating Pressure	Rod	2"
	Normal	1,100 psi
	Maximum	1,400 psi

CS-5 Specifications

GENERAL:

Dimensions	Length	48"
	Width	40"
	Height	41-1/2"
Clear Top Opening		21" L x 28" W
Load Height	Min	39-3/4"
Cycle Time		14 seconds
Ram Force	Normal	14,300 lbs
	Maximum	16,400 lbs
Ram Penetration		5.5"
Ram Face Dimensions		29-3/4 W x 18-3/4 H
Weight		1,186 lbs
WASTEC Rated		.26 CU YDS

CONSTRUCTION:

Chassis	Floor	1/2" Steel Plate 3" C-Channel
	Sides	7 gage 4" C-Channel
Presshead	Top	7 gage
	Sides	1/4" Steel Plate
	Face	1/2" Steel Plate
	Bottom	1/2" AR Steel Plate
	Guides	UHMW Pads
Breaker Bar		5" x 3-1/2" x 3/8" Steel Angle

ELECTRICAL:

Optional Voltage	Motor	5 hp
	Voltage	208-230/460 VAC 60 Hz Three Phase
		230 VAC 60 Hz Single Phase

HYDRAULIC:

Hydraulic Cylinder (2)	Pump Type	Vane
	Pump Capacity	6 gpm
	Tank Capacity	11 gal
	Bore	2-1/2"
	Stroke	18"
Operating Pressure	Rod	1-1/4"
	Normal	1,750 psi
	Maximum	2,000 psi

All information is subject to engineering and/or other changes without notice.

The CS series CS-01 saves up to 1/3 in space & accommodates up to a 6 yard Front Load Container

FEATURES

- Total unit UL/CUL listed
- Liquid limited capacity compactor/container
- Available with 2, 4 & 6 cubic yard container sizes
- Remote Power Unit
- Large Charge Opening
- Low loading height for easy loading
- Optional chute fed systems available
- Fully (UHMW) guided & supported ram
- ANSI Z245.21 Compliant

This compact combination offers a limited liquid sump trash containment system in a more compact size for space limitations. Designed to offer the same benefits of a larger unit with it's optional chute fed or hopper fed system.



DESIGN FEATURES

- Rugged Construction provides long life
- Compaction ratios average 4 to 1, depending on material
- Excellent Compaction of dry and/or wet material
- Ideal for Restaurants, Fast Food locations, Shopping Centers, Supermarkets, Apartments, Hospitals, Schools, Nursing Homes, and Hotels

LOADING CAPABILITIES

- Load from ground, off a dock, or through the wall

USER FRIENDLY

- CS-01 Container lid automatically unlocks when container is emptied and locks when returned

SAFETY

- Door Safety Interlock
- Removable key for authorized operator usage



with 2yd Can



with 4yd Can



with 6yd Can



CRAM-A-LOT®
 J.V. Manufacturing, Inc. 
 Solid Waste & Recycling Equipment

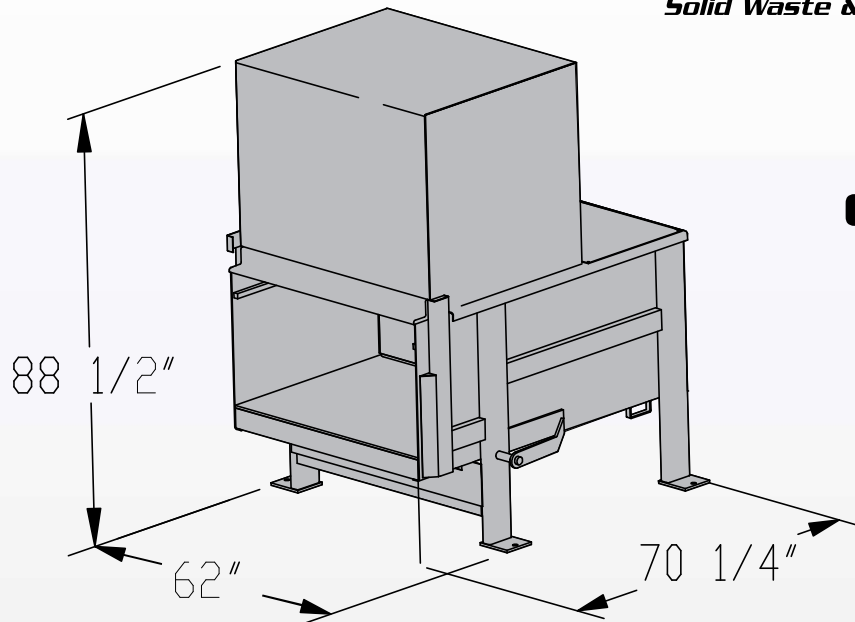

CS-01

Specifications

GENERAL:

Dimensions Length 70-1/4"
 Width 62"
 Height 88 1/2"

Clear Top Opening 35" L x 46" W

Load Height 49"

Cycle Time 58 seconds

Ram Force Normal 28,900 lbs
 Maximum 32,300 lbs

Ram Penetration 11"

Ram Face Dimensions 47 -3/4" W x 21" H
 Weight 3000 lbs

CONSTRUCTION:

Chassis Floor 1/2" Steel Plate
 4" C-Channel
 Sides 3/16" Steel Plate
 2" x 6" x 3/16" Steel Tube
 4" C-Channel
 Presshead Top 3/16" Steel Plate
 Sides 1/4" Steel Plate
 Face 1/2" Steel Plate
 Bottom 1/2" AR Steel Plate
 Guides UHMW Pads
 Breaker Bar 4" x 4" x 3/4" Steel Angle

ELECTRICAL:

Motor 5 hp
 Voltage 208 -230/460 VAC 60 Hz
 Three Phase

HYDRAULIC:

Pump Type Vane
 Pump Capacity 6 gpm
 Tank Capacity 12 gal
 Hydraulic Cylinder(2) Bore 3-1/2"
 Stroke 34
 Rod 1-1/2"
 Operating Pressure Normal 1,750 psi
 Maximum 2,000 psi

**CS-01
 with container**

	2 yd	4 yd	6 yd
OL	111"	123"	140"
OW	81"	81"	81"

All information is subject to engineering and/or other changes without notice.

Special modifications quoted upon request

The CS series CS-02 saves up to 1/3 in space & accommodates up to a 40 yard receiver

FEATURES

- Total unit UL/CUL listed
- Remote Power Unit
- Large Charge Opening
- Low loading height for easily loading
- Optional chute fed systems available
- Fully (UHMW) guided & supported ram
- ANSI Z245.21 Compliant

This compact unit offers the same 2 yd chamber as a standard size compactor but in a more compact size for space limitations. Designed to offer the same benefits of a larger unit with it's optional chute fed or hopper fed system.



DESIGN FEATURES

- Rugged Construction provides long life
- Compaction ratios average 4 to 1 depending on material
- Excellent Compaction of dry trash
- Ideal for Commercial or Industrial applications, Shopping Centers, Schools

LOADING CAPABILITIES

- Load from ground, off a dock, or through the wall

USER FRIENDLY

- CS-02 Allows 2yd compaction and 40yd capacity when the need for volume is required in tight spaces.

SAFETY

- Door Safety Interlock
- Removable key for authorized operator usage



Shown with 40 yd Octagonal Receiver



CRAM-A-LOT®
J.V. Manufacturing, Inc.
Solid Waste & Recycling Equipment

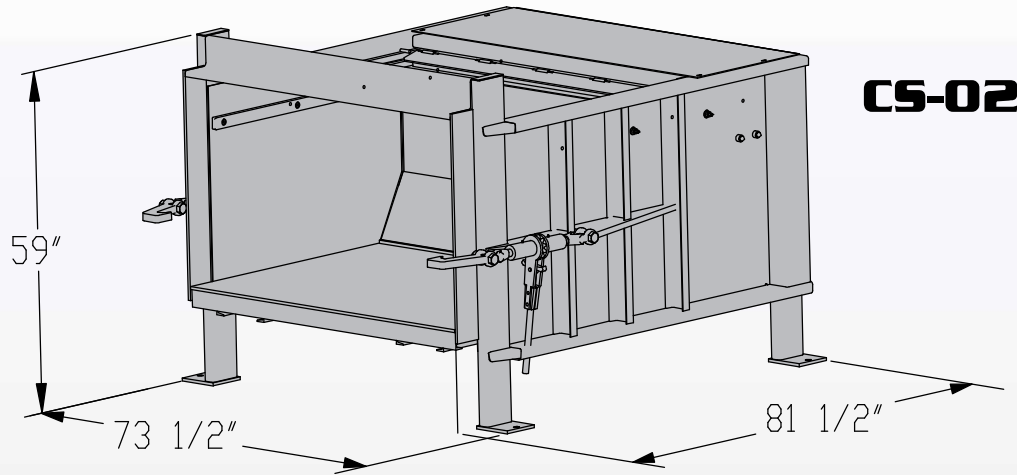

CS-02

Specifications

GENERAL:

Dimensions	Length	81-1/2"
	Width	73-1/2"
	Height	59"
Clear Top Opening		45" L x 58" W
Load Height		51"
Cycle Time		37 seconds
Ram Force	Normal	42,700 lbs
	Maximum	51,300 lbs
Ram Penetration		7 -1/2"
Ram Face Dimensions		60" W x 28" -11/16" H
Weight		4000 lbs
WASTEC Rated		1.56 CU YDS

CONSTRUCTION:

Chassis	Floor	1/2" Steel Plate 4" C-Channel
	Sides	3/16" Steel Plate 2" x 6" x 3/16" Steel Tube 4" C-Channel
Presshead	Top	3/16" Steel Plate
	Sides	1/4" Steel Plate
	Face	1/2" Steel Plate
	Bottom	1/2" AR Steel Plate
Breaker Bar	Guides	UHMW guide & support
		6" x 6" x 1" Steel Angle

ELECTRICAL:

Motor	10 hp
Voltage	208 -230/460 VAC 60 Hz
	Three Phase

HYDRAULIC:

Pump Type	Vane	
Pump Capacity	10.5 gpm	
Tank Capacity	22 gal	
Hydraulic Cylinder(2)	Bore	4"
	Stroke	34"
Operating Pressure	Rod	2"
	Normal	2,000 psi
	Maximum	2,400 psi

All information is subject to engineering and/or other changes without notice.

Special modifications quoted upon request



CRAM-A-LOT®

J.V. Manufacturing, Inc.

Solid Waste & Recycling Equipment



Leasing and Rental Programs Available

**Compactor Units can be custom designed
and factory installed to suit your special applications**

Cram-A-Lot® 1-2-3 Warranty

J.V. Manufacturing will furnish without charge:

- 1) All parts and labor expenses through the first year of ownership to remedy any faults proven to be the result of defective materials or workmanship.
- 2) All parts through the second year of ownership to remedy any faults proven to be the result of defective materials or workmanship.
- 3) All labor expenses through the third year of ownership to remedy any structural faults proven to be the result of defective materials or workmanship.

This warranty does not apply to any damage caused by negligence, misuse, modifications, alterations, or accidents by purchaser or third parties.
Refer to operation manual for specific warranty coverage.

CORPORATE OFFICE

P.O. Box 229
701 Butterfield Coach Road
Springdale, AR 72765

1-800-678-7320
479-751-7320
479-751-7774 (fax)

DISTRIBUTED BY:

www.cram-a-lot.com